



# 永恆環保機械有限公司 Wingbest Machinery Ltd

## Industrial Breaker Series

Breaker

Model : MPS-20

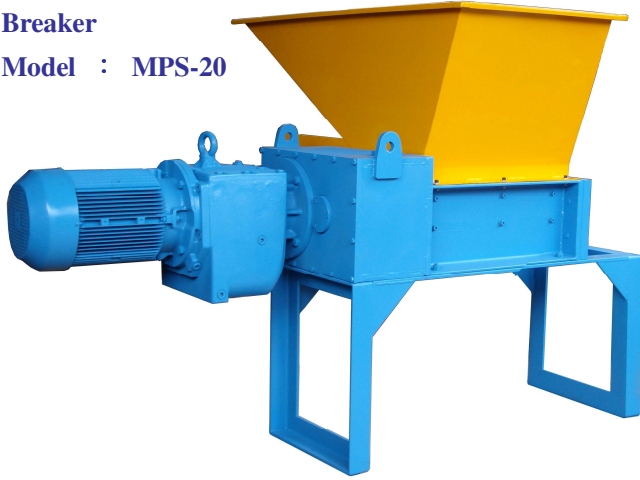

M/C Dimension : 2350L x 680W x 970H(m/m)

M/C Weight : 1010kg

### Characteristic and structure

- 1) Pair of axles , spiral feed type blade structure, best efficient breaking.
- 2) The cutting axles adopt and the special steel processed by NC, and then hardening by the heat treatment.
- 3) Horsepower adopts planet gearbox transmission, torsion is great, effective breaking, low noise, and also through conveyer belt installed to match the fully automation.
- 4) Suitable for breaking large plastics , plastic cap, timber, electric wire, aluminum pot, paper products ,etc.

## Powerful Twin Axles Breaker

型號 Model	機體入口尺寸 Inlet Size (mm)	刀片規格數量 Blade Spec (mm)	產量(O/P) Paper 紙類	馬力(匹) Power (HP)	轉速 Speed (RPM)	機器尺寸 Dimension L x W x H (mm)
MPS-20B MPS-20	350 x 700	16mm x 44pcs 30mm x 22pcs	1.2t/hr	20HP	30 rpm	2350 x 680 x 970
MPS-30B MPS-30	450 x 900	16mm x 52pcs 30mm x 26pcs	1.8t/hr	30HP	26~30 rpm	2350 x 810 x 970
MPS-40B MPS-40	450 x 900 450 x 1220	30mm x 26pcs 30mm x 40pcs	2.4t/hr 4.0t/hr	40HP 20HP x2	15~20 rpm 19~26 rpm	2350 x 950 x 1300 4370 x 950 x 1750
MPS-50B MPS-50	450 x 900	30mm x 28pcs 60mm x 14pcs	3.0t/hr	50HP	15~20 rpm	2350 x 950 x 1300
MPS-70B MPS-70	650 x 1220	30mm x 40pcs 60mm x 20pcs	4.5t/hr	60HP	26~30 rpm	4680 x 950 x 1750
MPS-75B MPS-75	720 x 1520	30mm x 50pcs 60mm x 25pcs	6t/hr	75HP	15~20 rpm	4980 x 1020 x 2050

香港廠：新界元朗洪水橋田心路 17 號 A  
17A Tin Sam Road, Hung Shui Kiu, Yuen Long, HK  
電話：2445 3555 傳真：2146 1126  
網址：www.wingbest.com.hk

國內廠：中國東莞市虎門鎮樹田村富安工業區  
電話：769-8555 5533/ 8555 4282  
傳真：769-8555 6826



永恆環保機械有限公司  
Wingbest Machinery Ltd

MPS-20 Breaker Dimension (mm)

(b)L x (c)W x (a)H

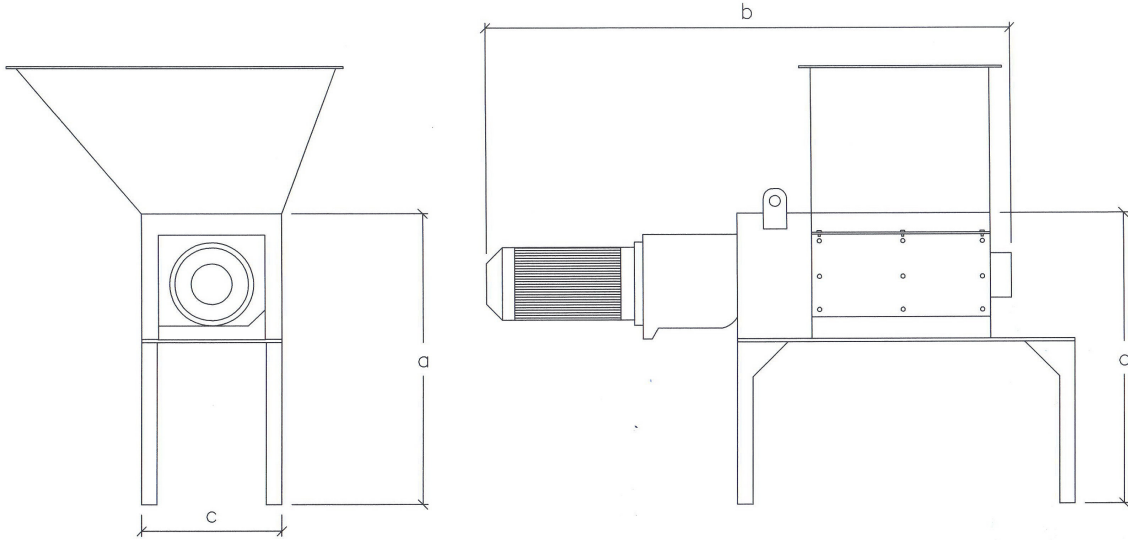

**Breaker**  
**Model :MPS-30**



**Breaker**  
**Model :MPS-70**

香港廠：新界元朗洪水橋田心路 17 號 A  
17A Tin Sam Road, Hung Shui Kiu, Yuen Long, HK  
電話：2445 3555 傳真：2146 1126  
網址：www.wingbest.com.hk

國內廠：中國東莞市虎門鎮樹田村富安工業區  
電話：769-8555 5533/ 8555 4282  
傳真：769-8555 6826