



永恆環保機械有限公司 Wingbest Machinery Ltd

Automatic hydraulic Waste Paper Baling Press System

Model type : ME-180

Suitable for large wasted paper recycle field
(handling for miscellaneous paper, newspaper,
paper, magazine)

Configuration : RF-650 Conveyor Belt / High Speed Inlet Stirring
Paper System / Automatic Wire-Tie System

-----This system only needs one forklift driver to achieve the following production output goal.



Baler Spec	Total Power : 150Kw (200 HP)	Main Pressing Power : 138,000kgf	M/C Weight : 26200kg
	Inlet Size : 1050W x 1750L	Inlet Capacity : 1.9 M ³	Compress Weight : 550kg/M ³
	Bale Size : 1100W x 1100H x 1600L	Bale Weight : 1060kg±5%	Wire/bale : 5 wires

The Main function include :

- ◆ Control Panel adopts PLC computer system can be chosen between automatic & manual operation, it is simple and easy control, safety and reliability.
- ◆ The errors & recovery signal can be shown clearly on dabbing type screen, those protective functions should avoided operation mistake and increase M/C life time.
- ◆ The full-automatic / manual RF650 conveyer belt adopts high load strength belt & install anti-slip flat plate.
- ◆ In order to increase life time, the paper jam / the shear obstacle device has designed to recover automatically which can be made the production running fast & smooth.
- ◆ All kind wasted paper material can be selected suitable range for bale size & weight in compressing channel by customers.
- ◆ The automatic wire-tie system adopts high strength TB0165AT case. The wire length counter can be set for selecting material to reduce wire knots and save wire consumption
- ◆ Dispose high-speed Stirring propeller machine which can be made the wasted paper distribute evenly in compressing channel. It can be increased the bale density & weight.
- ◆ With lower noise design to operate the higher turbo flow, the high flow can increase the utility conversion of main baler speed; the advantage of baler has saved energy, time, manpower, space area and rapid production.
- ◆ Can install the inlet separating system for large wasted paper recycle field which bale especially deal with miscellaneous paper, newspaper, paper, magazine etc.

ME-180 Bale Size : 1.1W x 1.1H x 1.6L (adjustable)

M/C Size : 8800 L x 4000 W x 6400 H(mm)

Output / hr Weight / Bale	32t / hr Miscellaneous Paper 1180kg ± 5%	32t / hr Newspaper 1180kg ± 5%	23t / hr Paper 1060kg ± 5%	30t / hr Magazine 1270kg ± 5%
------------------------------	--	--------------------------------------	----------------------------------	-------------------------------------

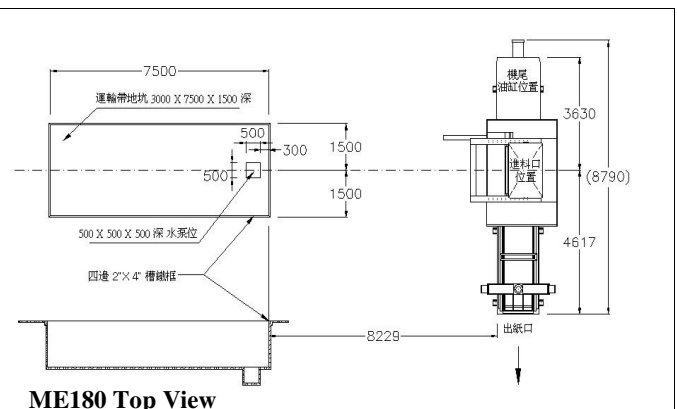
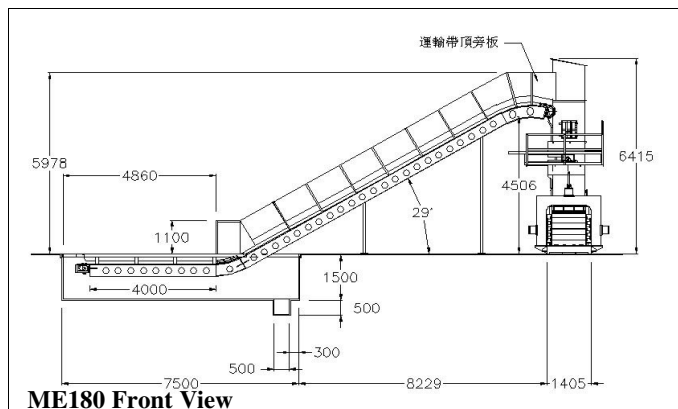

香港廠：新界元朗洪水橋田心路 17 號 A
17A Tin Sam Road, Hung Shui Kiu, Yuen Long, HK
Tel : 2445 3555 Fax : 2146 1126
Web Site : www.wingbest.com.hk

國內廠：中國東莞市虎門鎮樹田村富安工業區
電話：769-8555 5533/ 8555 4282
傳真：769-8555 6826
網址：www.wingbest.com.cn



永恆環保機械有限公司
Wingbest Machinery Ltd

Characteristic of the ME-180 Baling Press :

Main Motor	100HP/380V/50HZ	3PH	2 sets
Conveyor belt Motor	10HP/380V/50HZ	3PH	1 set
Stirring paper motor	30HP/380V/50HZ	3PH	1 set
Oil Pressure Pump	Main oil pressure blade pump (92 liter/min)		2 sets
	Auxiliary oil pressure blade pump (162 liter/min)		2 sets
Hydraulic pressure motor	Wire tie case TB0165AT		1 unit
Working Pressure	225kg/cm		
Main Pressing Power	138,000kgf		
Hydraulic Cylinder	Main hydraulic cylinder	∅ 280x2250mm	1 piece
	Wire pulling hydraulic cylinder	∅ 50x1550mm	2 piece
	Wire cut hydraulic cylinder	∅ 60x40mm	1 piece
	Paper cut hydraulic cylinder	∅ 100x460mm	1 piece
	Stirring propeller hydraulic cylinder	∅ 50x1080mm	2 pieces
	Movable plate of inlet hydraulic cylinder	∅ 50x630mm	2 pieces
	Compress trough hydraulic cylinder	∅ 200x120mm	3 pieces
Hydraulic Oil	AW68 of petroleum		
Capacity of the fuel tank	2400 liters (please keep oil level on upper limit for normal condition)		
Max Oil Temp.	>65°C (over 65°C would be alerted by alarm signal)		
Bale Size (mm)	1100Wx 1100Hx 1600L(adjustable)		
Bale Weight	Approx. 1060 kg ±5% (carton)		
Bale Speed	23-32 ton/hr		
Wire Diameter Spec.	2.8-3.2mm (2 times wire special treatment, 5 straps of bale tie)		
The Roll Of Wire Spec.	720mm external dia. × 500mm internal dia. (need to hold 10 rolls before operation)		

香港廠：新界元朗洪水橋田心路 17 號 A
17A Tin Sam Road, Hung Shui Kiu, Yuen Long, HK
Tel : 2445 3555 Fax : 2146 1126
Web Site : www.wingbest.com.hk

國內廠：中國東莞市虎門鎮樹田村富安工業區
電話：769-8555 5533/ 8555 4282
傳真：769-8555 6826
網址：www.wingbest.com.cn



永恆環保機械有限公司 Wingbest Machinery Ltd



Automatic hydraulic Waste Paper Baling Press System

Model type : **ME-180S**

Suitable for large wasted paper recycle field
(handling for miscellaneous paper, newspaper,
paper, magazine)

Configuration : **RF-650 Conveyor Belt / Automatic Wire-Tie System**

-----This system only needs one forklift driver to achieve the following production output goal.

Baler Spec	Total Power : 150Kw (200 HP)	Main Pressing Power : 138,000kgf	M/C Weight : 24600kg
	Inlet Size : 1050W x 1750L	Inlet Capacity : 1.9 M ³	Compress Weight : 550kg/M ³
	Bale Size : 1100W x 1100H x 1600L	Bale Weight : 1060kg±5%	Wire/bale : 5 wires

The Main function include :

- ◆ Control Panel adopts PLC computer system can be chosen between automatic & manual operation, it is simple and easy control, safety and reliability.
- ◆ The errors & recovery signal can be shown clearly on dabbing type screen, those protective functions should avoided operation mistake and increase M/C life time.
- ◆ The full-automatic / manual RF650 conveyer belt adopts high load strength belt & install anti-slip flat plate.
- ◆ In order to increase life time, the paper jam / the shear obstacle device has designed to recover automatically which can be made the production running fast & smooth.
- ◆ All kind wasted paper material can be selected suitable range for bale size & weight in compressing channel by customers.
- ◆ The automatic wire-tie system adopts high strength TB0165AT case. The wire length counter can be set for selecting material to reduce wire knots and save wire consumption
- ◆ With lower noise design to operate the higher turbo flow, the high flow can increase the utility conversion of main baler speed; the advantage of baler has saved energy, time, manpower, space area and rapid production.
- ◆ The suction inlet system can be chosen by customers. The baler is especially suitable for Printing Factory to handle the wasted paper edges; it is fully automatically to make the workshop without rubbish & dust.

ME-180S Bale Size : 1.1W x 1.1H x 1.6L (adjustable)

M/C Size : 8800 L x 4000 W x 6100 H(mm)

Output / hr Weight / Bale	32t / hr Miscellaneous Paper 1180kg ± 5%	32t / hr Newspaper 1180kg ± 5%	23t / hr Paper 1060kg ± 5%	30t / hr Magazine 1270kg ± 5%
------------------------------	--	--------------------------------------	----------------------------------	-------------------------------------

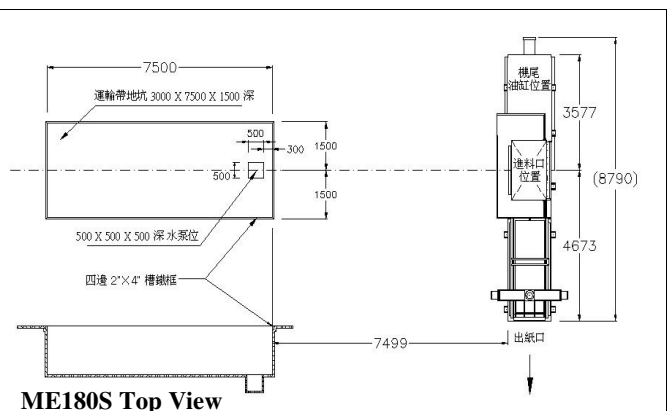
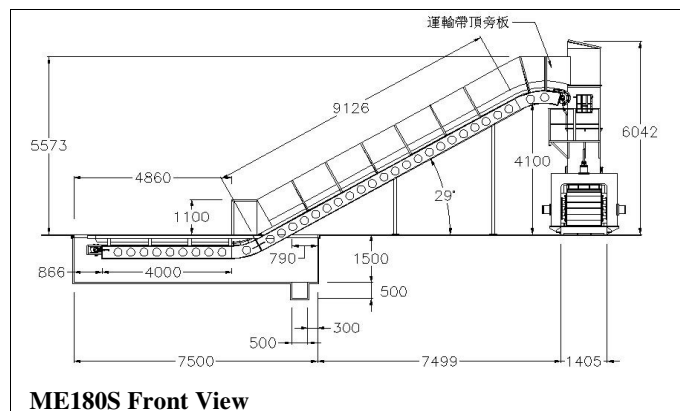

香港廠：新界元朗洪水橋田心路 17 號 A
17A Tin Sam Road, Hung Shui Kiu, Yuen Long, HK
Tel : 2445 3555 Fax : 2146 1126
Web Site : www.wingbest.com.hk

國內廠：中國東莞市虎門鎮樹田村富安工業區
電話：769-8555 5533/ 8555 4282
傳真：769-8555 6826
網址：www.wingbest.com.cn



永恆環保機械有限公司
Wingbest Machinery Ltd

Characteristic of the ME-180S Baling Press :

Main Motor	100HP/380V/50HZ	3PH	2 sets
Conveyor belt Motor	10HP/380V/50HZ	3PH	1 set
Oil Pressure Pump	Main oil pressure blade pump (92 liter/min)		2 sets
	Auxiliary oil pressure blade pump (162 liter/min)		2 sets
Hydraulic pressure motor	Wire tie case TB0165AT		1 unit
Working Pressure	225kg/cm		
Main Pressing Power	138,000kgf		
Hydraulic Cylinder	Main hydraulic cylinder	∅ 280x2250mm	1 piece
	Wire pulling hydraulic cylinder	∅ 50x1550mm	2 piece
	Wire cut hydraulic cylinder	∅ 60x40mm	1 piece
	Paper cut hydraulic cylinder	∅ 100x460mm	1 piece
	Compress trough hydraulic cylinder	∅ 200x120mm	3 pieces
Hydraulic Oil	AW68 of petroleum		
Capacity of the fuel tank	2400 liters (please keep oil level on upper limit for normal condition)		
Max Oil Temp.	>65°C (over 65°C would be alerted by alarm signal)		
Bale Size (mm)	1100Wx 1100Hx 1600L(adjustable)		
Bale Weight	Approx. 1100 kg ±5%		
Bale Speed	23-32 ton/hr		
Wire Diameter Spec.	2.8-3.2mm (2 times wire special treatment, 5 straps of bale tie)		
The Roll Of Wire Spec.	720mm external dia. × 500mm internal dia. (need to hold 10 rolls before operation)		

香港廠：新界元朗洪水橋田心路 17 號 A
17A Tin Sam Road, Hung Shui Kiu, Yuen Long, HK
Tel : 2445 3555 Fax : 2146 1126
Web Site : www.wingbest.com.hk

國內廠：中國東莞市虎門鎮樹田村富安工業區
電話：769-8555 5533/ 8555 4282
傳真：769-8555 6826
網址：www.wingbest.com.cn